

Installation instructions

Dynamic SoundField

The following materials are included (if any are missing, contact your local Phonak dealer):

DigiMaster 5000 package

A B C D

Optional: Stand plate package

F G H

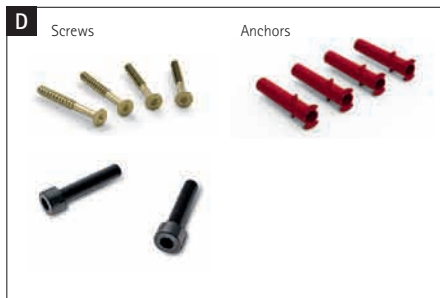
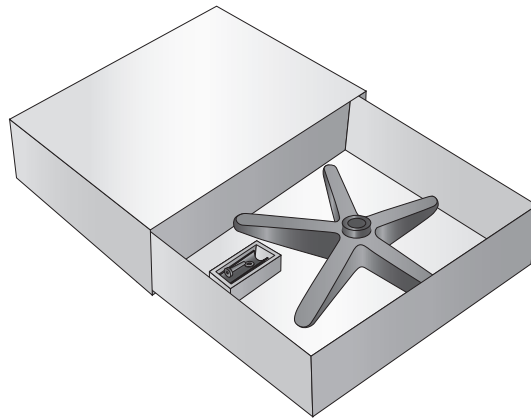
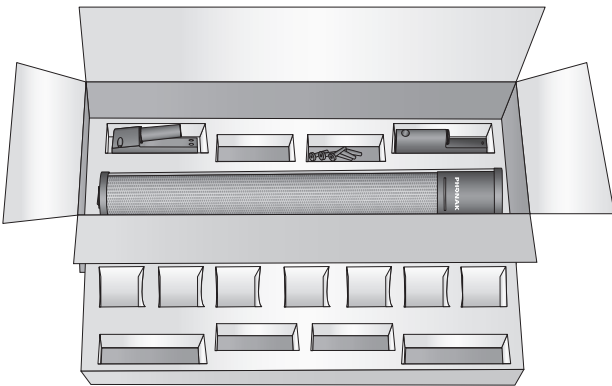

Optional: Stand tube package

I

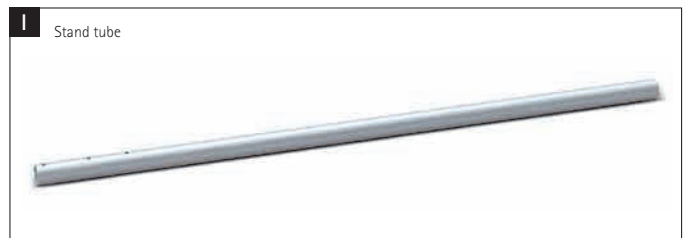

Follow these installation instructions carefully to make sure your Dynamic SoundField system is properly installed.



Dispose of the packaging material as per local regulations.

Installation instructions

Dynamic SoundField

The following tools are required for the installation:

To mount the loudspeaker on the wall:

- Drill with 5mm bit
- Spirit level
- Pencil
- Torx screwdriver T20*
- Hex wrench 5*

To mount the loudspeaker on the floor stand:

- Hex wrench 5*
- Hex wrench 6*

*Delivered from Phonak

1. Selecting the right location

1) Identify an open and safe place, ideally in front of the class. e.g. on the right or left side of the Smartboard or blackboard.



2) Make sure there is a power source nearby.

2. Installation

If you plan to use the DigiMaster 5000's floor stand, go directly to chapter 2.2: Mounting the DigiMaster 5000 on its stand.

2.1 Mounting DigiMaster 5000 on the wall

1) Measure 1.40 meters (4 feet) up from the students' floor level and mark the wall with a pencil.

Hold the wall support [B] against the wall so that the pencil mark is at the bottom of the wall support. Adjust the wall support using the spirit level until it is level. Use the pencil to mark the wall through the wall support's four holes.

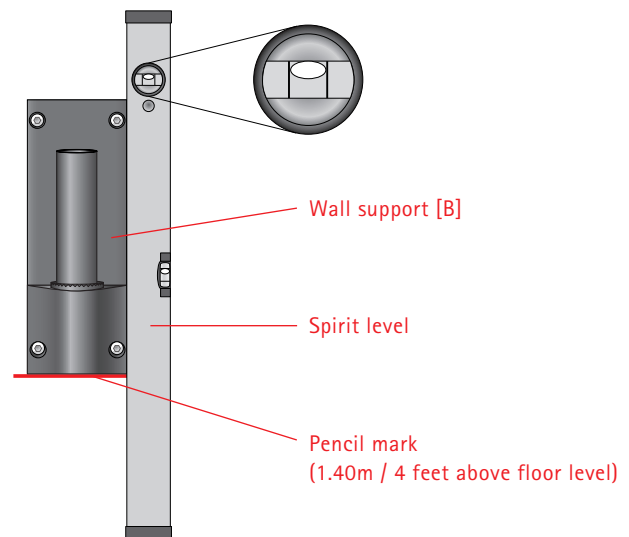

2) Remove the wall support and drill 4 holes using a 5mm (0.2 inches) diameter drill bit. The depth of these holes should be at least 30mm (1.2 inches).

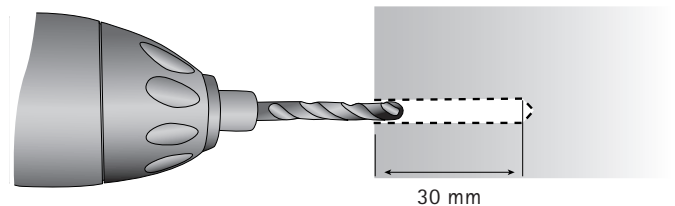

3) Push the anchors [D] into the holes. Mount the wall support using the 4 torx screws [D] and a torx T20 screwdriver.

Installation instructions

Dynamic SoundField

4) Mount the array fixation [C] on the DigiMaster 5000 by using the two black hex screws [D] and hex wrench 5.



5) Carefully attach the DigiMaster 5000 [A] to the wall support and turn it to face the center of the class.

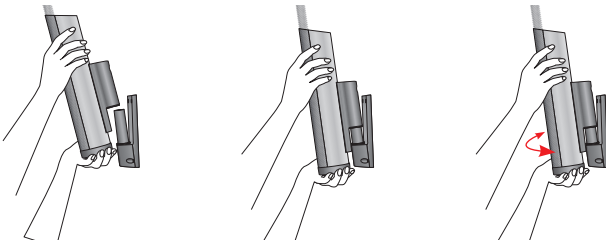

6) Attach the power cable to the power adapter [E]. Plug the power cable into the mains and the 19Volt jack into the socket on the bottom of the DigiMaster 5000. Your DigiMaster 5000 is now ready to be paired with the inspiro.

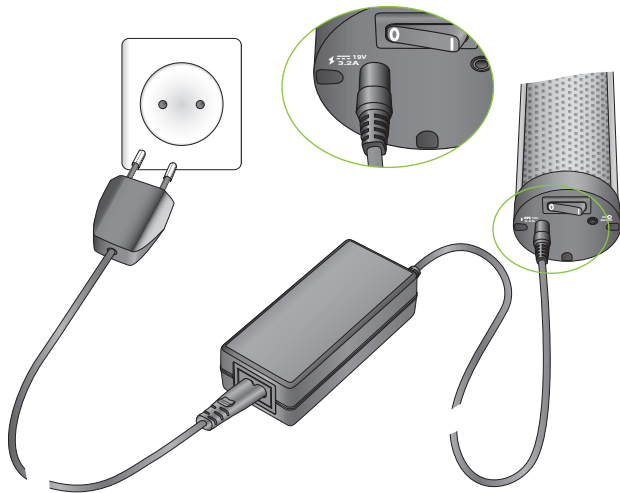

Make sure the power cable is safely positioned!

Now go directly to chapter 3: Pairing the DigiMaster 5000 with the inspiro.

2.2 Mounting the DigiMaster 5000 on its stand

1) Take the plate [F], stand tube [I], black M8 screw and M8 washer [H].

2) Gently place the 'screw thread' end of the tube stand in the center of the plate (see picture below). The three holes are on the upper side of the stand. Fix the tube from the underside of the plate, using the screw M8, washer and hex wrench 6. Place the stand on the floor.

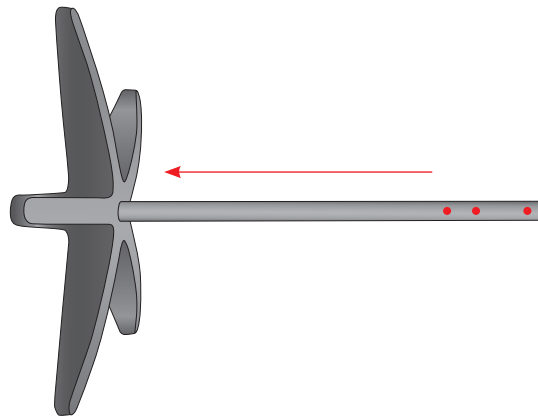

3) Take the DigiMaster 5000 and the tube connection [G]. Hold the tube connection behind the DigiMaster 5000, where the 4 holes are situated. The two fingers of the tube connection should fit into the two inner holes.



4) Take the two black hex screws [D] from the wall mount kit and push these through the two holes in the upper part of the stand tube. Screw the DigiMaster 5000 featuring the tube connection to the tube using hex wrench 5.



Installation instructions

Dynamic SoundField

5) Attach the power cable to the power adapter [E]. Plug the power cable into the mains and the 19Volt jack into the socket on the bottom of the DigiMaster 5000. Your DigiMaster 5000 is now ready to be paired with inspiro.

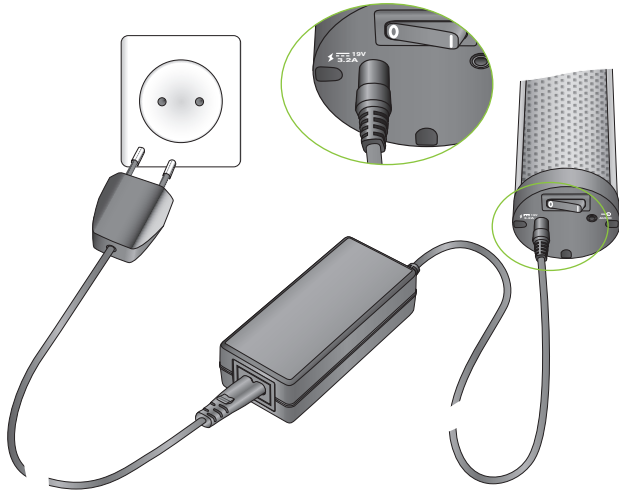

Make sure the power cable is safely positioned!

3. Pairing the DigiMaster 5000 with the inspiro

1) Take inspiro and make sure it is charged (see the Dynamic SoundField User Guide). Switch on inspiro. If the battery symbol appears, press the two buttons shown below-left simultaneously.



2) Release the two buttons then press OK.

3) You will now see the inspiro installer menu. Select "Pairing". inspiro will now guide you through the pairing process. Please follow the instructions provided:

a) When you see three dots on the inspiro LCD, hold inspiro close to the loudspeaker (nearer than 1 meter / 3 feet) and switch on the DigiMaster 5000.

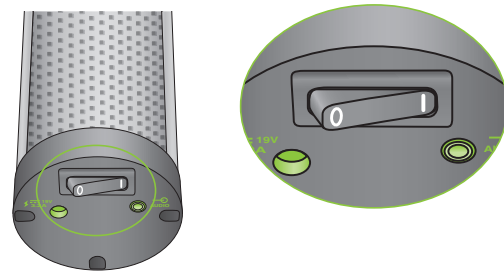

b) After a short time, inspiro will inform you that the loudspeaker has been paired. The LED color of the DigiMaster 5000 will now display a constant blue light. This blue light shows that the Dynamic SoundField system is ready for operation.

4) If not required immediately switch off both inspiro and the DigiMaster 5000. Dynamic SoundField's installation is complete.



Please check the Dynamic SoundField User Guide to learn about the standard functionality of Dynamic SoundField.